

Sample

Residential Garden Design with Vectorworks Landmark by Tamsin Slatter





Sample





Sample

Residential Garden Design with Vectorworks Landmark by Tamsin Slatter



Residential Garden Design with Vectorworks Landmark, Version 2009

Published by Nemetschek North America, Inc





Sample



Tamsin Slatter, Vectorworks Training.
Hermitage, Berkshire, United Kingdom
Phone: +44 845 003 7066

Email: tamsin@vectorworks-training.co.uk

Copyright

© 2007-2008 Nemetschek North America, Inc. and Tamsin Slatter

All rights reserved. No part of this book may be reproduced or transmitted in any form by any means, electronic or mechanical, including photocopying, recording, faxing, emailing, posting online or by any information storage and retrieval system, without prior written permission of the publisher. Published in the U.S.A.

Trademarks

Vectorworks is a registered trademark of Nemetschek North America, Inc. in the U.S. and other countries. Windows is a registered trademark of Microsoft Corporation in the U.S. and other countries.

Macintosh is a trademark of Apple Computer, Inc., registered in the U.S. and other countries. Adobe, Acrobat and Reader are registered trademarks of Adobe Systems in the U.S. and other countries.

Notice of Liability

The information in this book is distributed on an "as is" basis, without warranty. While every precaution has been taken in the preparation of this book, neither the author nor Vectorworks Press shall have any liability to any person or entity with respect to any loss or damage caused or alleged to be caused directly or indirectly by the information contained in this book or by the computer software described in it.

For more Vectorworks training information, or to purchase more copies of this book, please visit www.vectorworks.net/training or call us at (410) 290-5114.

Copyright 2008-2009 Nemetschek North America, Inc. and Tamsin Slatter. It is unlawful to copy this book in any manner. For permissions, contact publications@vectorworks.net. For additional copies, please visit www.vectorworks.net/training.





Table of Contents

Sample

Introduction - How to Use this Book vi

Setting up the Drawing Board..... 1

Exercise One: Ensure you are Working in the Landmark Workspace.....2

Exercise Two: Set Up Your Vectorworks Preferences3

Exercise Three: Managing Other Vectorworks Settings7

Exercise Four: Set Default Font8

Exercise Five: Set Up Your “Drawing Board” and Save Your Template.....8

Adding Color and Pattern to Objects 15

Exercise Six: Applying Graphic Attributes to 2D Objects..... 16

Setting Up Your Resource Browser 25

Exercise Seven: Getting to Grips with the Resource Browser 26

Exercise Eight: Creating a Personal Resource Library 31

How to Import a Surveyor’s or Architect’s File 41

Exercise Nine: Importing Survey/Architect’s Files 41

Exercise Ten: Reviewing the Layers and their Scale..... 45

What to Do When it Doesn’t Work Like the Book Says .. 53

Exercise Eleven: Importing Multiple Files and Re-positioning on the Page 55





Sample

Exercise Twelve: Importing Images..... 57

Drawing Up Your Own Site Survey..... 61

Exercise Thirteen: How to Draw the House..... 61

Exercise Fourteen: Creating and Positioning Doors and Windows..... 66

Exercise Fifteen: Locate Points by Triangulation..... 74

Exercise Sixteen: Locate Points Using Offsets 76

Exercise Seventeen: Drawing Up Curves Measured Using the Offset Method..... 79

Exercise Eighteen: Adding Level Data 81

Exercise Nineteen: Drawing up the Property Line Where You Have a Plat..... 82

Setting Out a Design 85

Exercise Twenty: Create a Setting Out Plan 85

Using Text and Dimensions to Annotate your Plan..... 99

Exercise Twenty–One: Add Some Text 99

Exercise Twenty–Two: Adding Dimensions to the Plan..... 102

Working with Hard Landscaping..... 107

Exercise Twenty–Three: Set Up the Resources and File Organization..... 108

Exercise Twenty–Four: Creating Walls and Steps..... 110

Why Use the Hardscape Tool? 117

Exercise Twenty–Five: Creating Surfaces Using the Hardscape Tool..... 118





Sample

Reporting on How Much of Each Material You've Used	129
Exercise Twenty-Six: Create a Report to Show Your Hard Landscaping Areas	129
Exercise Twenty-Seven: Create Individual Symbols to Represent Hard Landscaping.....	131
Exercise Twenty-Eight: View it all in 3D.....	136
Adding Lighting to a Garden Plan.....	141
Exercise Twenty-Nine: Adding Some Lighting to the Plan.....	142
Creating Additional 3D Objects.....	149
Exercise Thirty: Using More 2D/3D Hybrid Tools.....	149
Exercise Thirty-One: Adding Finishing Touches	152
Creating 3D Solids From 2D Shapes	156
Exercise Thirty-Two: Creating a Planter Using Extrudes	159
Exercise Thirty-Three: Creating a 3D Pergola.....	161
Creating 3D Curves and Surfaces	166
Exercise Thirty-Four: Create a Sail Shade	167
Planting Plans.....	173
Exercise Thirty-Five: Adding Some Plants to Your Design	174
Exercise Thirty-Six: Placing Plant Objects Using the Place Plant Tool.....	176
Exercise Thirty-Seven: Creating Your Own Plant Definitions	181
Exercise Thirty-Eight: Editing Plant Definitions to Changing Their Appearance.....	186





Sample

Exercise Thirty-Nine: Creating a Plant From Your Own Symbols 187

Exercise Forty: Adding a 3D Symbol to a Plant Object 188

Creating Mixed Planting Areas 189

Exercise Forty-One: Create a Landscape Area 191

The Vectorworks Plant Database 193

Exercise Forty-Two: Adding Local Data to Your Database 194

Exercise Forty-Three: Importing Your Own Plant Data From Another File 195

Producing a Plant Schedule Report 196

Exercise Forty-Four: Using the Pre-made Plant List 197

Exercise Forty-Five: Defining Your Own Plant Schedule 198

Defining the Planting Beds with Plant Graphics 198

Creating Perspective Views of the Garden 201

Exercise Forty-Six: Using Renderworks Cameras 201

**Getting Ready to Print – Viewports, Sheets and Sections .
205**

Exercise Forty-Seven: Preparing a Drawing for Printing 205

Exercise Forty-Eight: Creating a Hard Landscaping Plan 213

Exercise Forty-Nine: Creating a Planting Plan Sheet 216

Exercise Fifty: Creating Electronic Drawing Files in a Variety of Formats 217





Sample

Summary	220
Acknowledgements	221





Introduction - How to Use this Book

Sample

When I was asked to write this book I was delighted. It brings together two subjects about which I am passionate—garden and landscape design—and Vectorworks Landmark.

The book has been designed as a workbook that covers the typical work stages of the Landscape Garden Designer. You will start with setting up your environment, then move through the various stages of the design process in order to create a garden which is both 2D and 3D.

It is not designed to make you a complete expert in Vectorworks. It is designed to build a foundation of essential knowledge to help you understand the way Vectorworks is intended to work within your design discipline. It complements the information provided in the free guides discussed below, and the extensive Help system which is installed on your machine with the software.

You will need Vectorworks Landmark 2009 software and Renderworks is recommended in order to gain the maximum benefit from the workbook and indeed Vectorworks.

Before you Start

This book builds on the basic skills covered in the two free guides that cover the basics of drawing in both 2D and 3D. It is recommended that you use these guides first. They can be downloaded from:

http://www.nemetschek.net/training/free_resource.php

- QuickStart to Landmark
- Getting Started with Vectorworks Landmark 2009

In addition, if you are completely new to using a computer, it would be really useful if had a basic understanding of the following:

- How files and folders are organized on a computer
- How to open files
- How to save files

This information is available on the Microsoft and Apple Web sites, so if you're completely new to using a computer, I recommend you look at some of their free training videos.



How to Use this Manual

This manual comes as a hard printed copy with one CD-ROM. The CD contains an exercise folder called “Landmark 2009 Exercises”. Copy the exercise folder to a file location of your choice on your computer such as “My Documents” to make it easy to find the files. Save any training files you work on to your exercise folder.

I recommend that to start with, you work through the book from end to end, using the examples on the accompanying CD. You may look at a subject and think you are already using those tools, but it’s always worth working through as you may still learn something. Vectorworks is huge so you can learn something new all the time.

I have written the workbook in such a way that once you’ve mastered the basics, you can dip in and out of the book as needed and keep it by you as a handy reference. Some chapters will be essential to learn before you can go further—like the basics of setting up your drawing board and Resource Browser. But after that, if you want to remind yourself about the hard landscaping you can just go straight to that section. At each stage, I’ve provided a completed sample file with the chapter, so that you can compare your results with mine. Therefore you can pick up the book and start at any place by opening the completed file for the previous chapter.

Vectorworks Environment Used in this Book

The book covers both the PC running Windows and the Apple Mac running MacOS. However, the exercises and screenshots have been developed on a PC environment, with Windows XP as the operating system. Where instructions for each environment differ, I have noted this with the use of the following text:

- Apple
- PC

Having installed Vectorworks, you should start with the guides that were delivered with your software, as they will take you through the basics of drawing and give you some familiarity with the environment. This book is not intended to replace the extensive Help system that installs with the software. While it does not cover industry workflows, the Help will give you in-depth supplementary information on the tools you will use in this book. With Vectorworks, there are always many ways to achieve something and whichever way works best for you is the one to stick with.

The book is based on Vectorworks 2009 Landmark with Renderworks and includes exercise files in the Vectorworks 2009 format. Therefore, you will need a copy of the software in order to use it. This could be a demonstration copy, an Educational License or a Full License. Some





Sample

of the exercises require Renderworks also. If you don't have Renderworks it won't stop you using this book but it you won't be able to complete some of the exercises and achieve the same finished look in some cases.

Typing Conventions in this Book

Exercises are clearly noted and their instructions are shown as follows:

1. This is step one of this exercise.

Wherever menus and tools are discussed in this book, their names are written exactly as you will find them in the application. The location of each tool is described in the instruction. Tools can display their names in their respective palettes or can display their name when you hover the mouse over them. An example is as follows:

2. Use the Circle tool found in the Basic palette. Change the mode of the Circle tool to Circle By Diameter Mode using the Tool bar.

Exercises may also contain lists of instructions within one numbered step. These are shown as a bulleted list. In the example below you should type the value 1000 in Box A:

- Box A: 1000
- Box B: 2000

Wherever I refer to specific keys on the keyboard, I've used capital letters to distinguish the key from Vectorworks menus and tools. For example:

3. To constrain the line to a 45° angle, hold down the SHIFT key while drawing.
4. Save the file using CTRL/⌘ +S

Regional Variations – Language and Measurements

Despite being born and bred in the UK, I have done by best to write this book in American English to reach that wider audience! For example, here in the UK, we have spanners, whereas in the US there is no such thing as a spanner, but there is a wrench instead.

The book also covers both metric and imperial measurements. My primary measurements are in millimeters or meters, but I have also translated into imperial. Sometimes these measurements are an exact translation whereas sometimes they are a more sensible translation. For example:





Sample

500mm has been translated as 1'6" whilst the exact translation would be 1' 7 5/8". In this book, this is written as follows:

1. Draw an object with the following dimensions:

- Width: 500mm (1'6")

When I am training new users, there is often much discussion as to why some use metric and some use imperial. A recent discussion with other Vectorworks users made it clear to me that the two systems are widely used in many cultures. For example, here in the UK, we draw in millimeters or meters, buy paving by the square meter, but buy timber with imperial dimensions. We also measure rainfall in inches and fill our cars with liters of fuel. But we measure the consumption of fuel in miles per gallon. At the end of the working day we may go to the pub for a quick pint of beer! So, tolerance and the ability to convert is crucial.

Approximate Metric to Imperial Conversion

In the table below, you will find some common metric to imperial conversions - they are approximate and make the most sensible translation.

Metric	Imperial
25 mm	1"
100 mm	4"
150mm	6"
0.3m	1'
0.5m	1'6"
1.5 m	5'
1.8m	6'
3m	10'
10m	33'





English / American Phrase Book

In putting together this book, I have also discovered the joys of a common and yet very different language! This table includes some of the words I use in my English-English and how they translate to American-English!

English	American
Spanner	Wrench
Label	Tag (also means graffiti in France)
Biscuit	Cookie
Maths	Math



Windows vs. Mac



The Vectorworks software generally behaves identically on the Mac as it does on the Windows environment. However, there are certain differences on the keyboard which are noted here.

Windows key	Equivalent Mac Key
Control (or Ctrl)	Command (or ⌘)
Delete	Some Mac keyboards don't have a delete key and use the Backspace key instead (←)

Sometimes, I've suggested keystrokes that can be used as shortcuts. For example, the Control key held down with the S key can be used to save a file without having to go to the File menu. Where I've written such shortcuts, I've shown Windows first and then the Mac equivalent as follows:

1. Save your file using File/Save or by using CTRL+S/⌘+S on your keyboard.

Now it's time to get started!





Setting up the Drawing Board

By the end of this chapter, you will have an understanding of how to set up your Vectorworks drawing area so that it's ready for you to work in the way that's best for you each time you start a new project. If you're making the transition from hand-drawing to working on a computer, you can liken this process to that of setting up your drawing board. If you were drawing by hand, you would start by choosing the size of paper you wish to work on, and then select an appropriate scale for your drawing and so on. We will do the same here. Once you've set up your most common ways of working, you'll be able to save them so that you don't need to repeat the setup each time you work.

There are many options for setting up the system and some of them may appear meaningless to you. Remember that Vectorworks is an extremely powerful tool that covers many different design disciplines. If those settings aren't appropriate to garden design, we won't cover them so you can be assured that we'll be focusing only on the things you need.

Some of the things I'm going to take you through in this chapter may not make complete sense to you yet. For example, you may still be feeling a little unsure about the concept of classes and layers. Don't worry, it will all become clearer as you work through the book. At this stage, we are ensuring that we have the system setup in a way that will work well for you.

About the Different File Types Vectorworks Creates

Vectorworks files have a .vwx file extension and are saved in the directory you designate – for example c:\Documents\ClientA\ClientA.vwx.

Vectorworks backup files, created by the automatic backup facility we'll set up later in this chapter, have a .vwx extension too.

Vectorworks template files have a .sta file extension. A template is a file that contains all the things you want to include in every file. We will create a template at the end of this chapter. You can create as many templates as you like in order to cater to different working scenarios.

The Landmark Workspace “Drawing Board”

The workspace contains the “drawing board” together with all the drawing tools and menus you need arranged around it. You can't drop the tools off the edge of your board and the ink doesn't dry up either! Some of these tools are arranged on palettes and some are arranged on menus. The diagram below shows the Landmark layout and the main items you will use to create your drawings. The term “workspace” means a named definition of the way the tools and menus are laid out for you. Throughout this workbook, we're going to use the Landmark Workspace. As you become more proficient with the system you can, if you wish, edit the workspace or even create your own—if you've been used to using another system you may wish to customise the workspace to make it more familiar. At this stage, though, I suggest you learn the Landmark Workspace as it is.



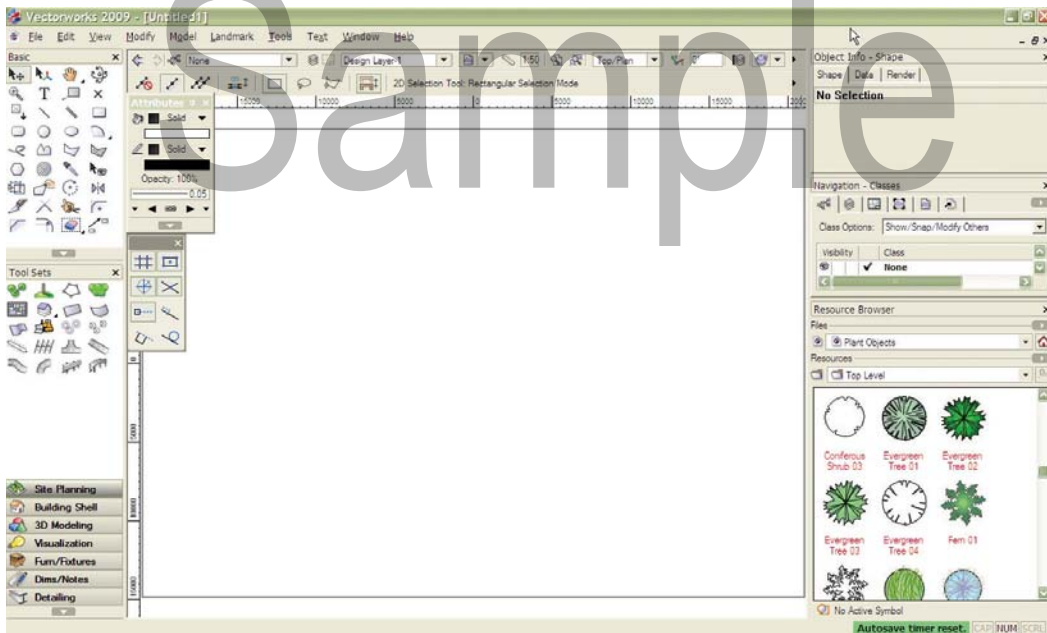

If you're using Windows, the "palettes" containing tools and utilities can be "docked". This means that they are "stuck" to the side of the screen and do not overlap the drawing area. If you're new to drawing on a computer, it's easy to unwittingly remove palettes from the dock or close them completely. If you have "undocked" them and want to move them back to their home, you can click and drag their heading onto the heading of another palette which will lock them back into position. Alternatively, you can have all your palettes "floating" so that they move independently. They can also be set to roll up completely so that they only open when you place the mouse pointer on them. On the top right of the palette, you'll see a little icon that looks like a map-pin. Click on this to "unpin" the palette. It will close when you move the mouse away from it.

On a Mac, the palettes can't be docked and always move as independent windows—this is not a Vectorworks design issue but, rather, the way the Mac operating system works.

Palettes can also be closed by clicking on the small x on the top right (Windows) or the red button at the top left (Mac). If you close a palette by accident, it can be opened using the Windows / Palettes menu.

Along the top of the screen, just below the menu, is an area known as the View bar. You can change which buttons are displayed on this. If you are using a mouse I recommend that you remove the zoom options as you can zoom with your mouse.

Exercise One: Ensure you are Working in the Landmark Workspace

1. From the Tools menu, choose Workspaces, then select Landmark from the list.



2. The windows and palettes on your screen will disappear temporarily as the workspace re-starts, but don't panic—they will all re-appear.
3. If you're using Windows on a PC, click on the heading of the palette named Object Info and drag it. Notice that it's become a floating palette.
4. Click on the map-pin icon on the top right of the palette and click on a blank space on the drawing. Notice that the palette closes, leaving just its heading visible.
5. Roll your mouse over the palette again and notice it opens. Click on the map-pin icon again to pin the palette open.

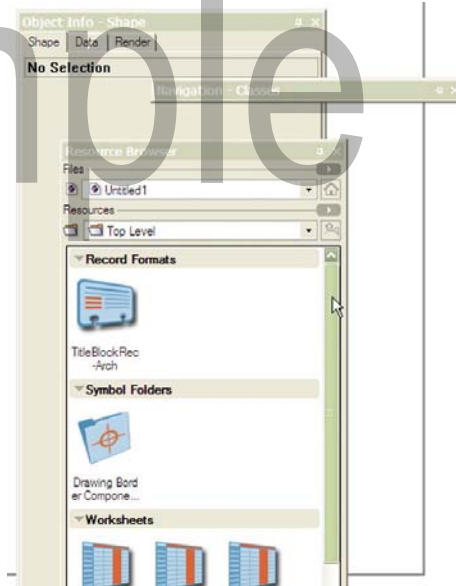

6. Drag the heading of the palette over the heading of the Navigation palette (still docked). Notice that the Object Info palette is now docked again.
7. Notice the scroll bar on the right of the Resource Browser palette. Use your mouse to move the slider up and down to reveal more information on the palette.
8. Now we'll change the view bar to show the layer scale button instead of the Zoom buttons - if you are using a mouse you won't need the zoom. Click on the arrow at the top right of the screen. This will drop down a menu. Click next to Zoom to remove it. Click next to Layer Scale to add it. This makes better use of the space and gives you a shortcut to changing your layer scale.

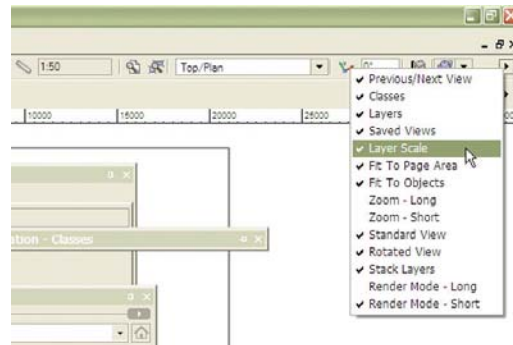

Exercise Two: Set Up Your Vectorworks Preferences

Changes made to Vectorworks Preferences will affect the way Vectorworks runs each time it is started on your computer. The changes are not limited to the current drawing but apply each time you open the program. I'm going to take you through my recommended settings but I'm not going to go into huge detail here about what each means – the Help system is really good for that. My aim is to give you a setup that will get you up and running in a sensible way, as quickly as possible. Note that you can also hover your mouse over each of the options to get a description of what the option does.





Sample

1. From the Tools menu, choose Options, then Vectorworks Preferences.
2. Work through each of the tabs, making selections as I recommend below:

Edit Tab

1. Ensure the following boxes are checked:
 - Eight reshape handles
 - Offset duplications
 - Auto join walls
 - Mouse wheel Zooms
2. Set 2D conversion res to Very High
3. Leave Default compression to PNG
4. Set Nudge objects to Arrow, so that when you select objects, you can use the arrow keys to move them very precisely, one pixel at a time.



Note: If you've used other drawing packages, you may find that Click Drag drawing is more familiar to you than the default Click-Click style of drawing. This setting is also best if you are working with a tablet instead of a mouse. However, I recommend you stick to Click-Click while using this workbook.

Display Tab

1. These preferences affect the way things are displayed and are mostly self-explanatory. Ensure the following are checked:
 - Rulers
 - Scroll Bars (only if you don't have a mouse with a wheel)
 - Adjust flipped Text
 - Show parametric constraints
 - Show other objects while in editing modes along with Gray other objects
 - Use VectorCaching for faster drawing
 - Center on objects after view change
 - GDI+ imaging (Quartz imaging on a Mac) and Anti-aliasing

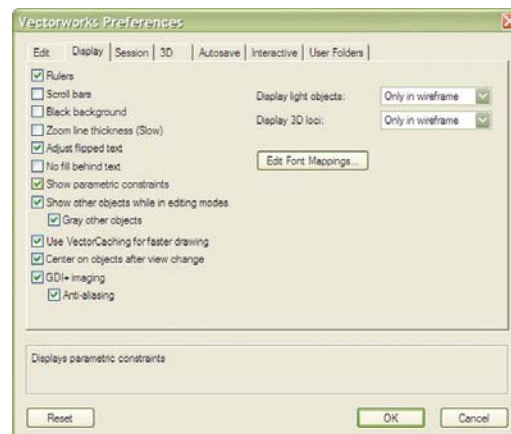



- Display light objects: Only in wireframe
- Display 3D loci: Only in wireframe

2. Click on the Font Mapping table as this will allow you to decide what happens to fonts included in files that you import from other sources. If you do not have the same fonts installed, you may want Vectorworks to automatically convert the fonts to your own “house” font.

Session Tab

1. In this tab, I would certainly recommend that you switch off sound—otherwise you get an irritating click every time you move the cursor across your screen. If you’re working in an office with other people, it can put a huge strain on friendships! Preferences I recommend turning on are:

- Log time in program
- Display minor alerts on message bar
- Maximum number of undos: 20
- Issue undo warnings
- Undo view changes: Never (unless you want each view change to be considered an “action” by Vectorworks).
- Enable palette docking (Windows only)
- Display default content
- Automatically check for updates: Weekly

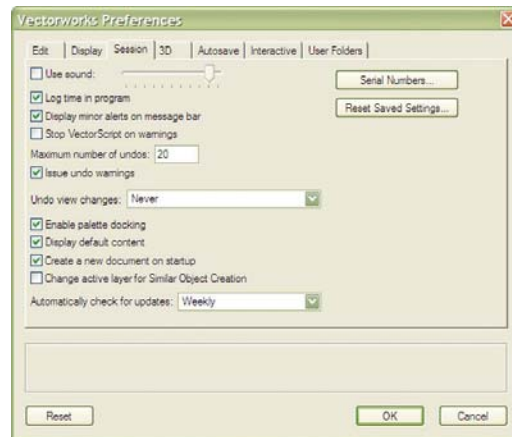

3D Tab

These preferences describe how Vectorworks will handle the display of 3D objects.

1. If memory and processing power is not a problem, set the following:
 - 3D rotation to Responsive and Retain Rendering Model to Always.
 - Switch on 3D axis labels, as they will help with orientation when you are working in 3D.

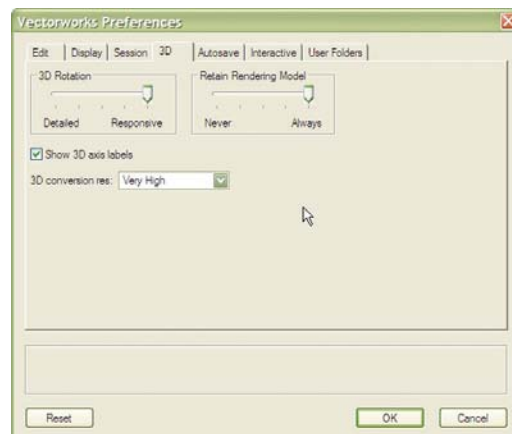

Autosave Tab

This tab is *incredibly important!* If you're moving from hand-drawing, your common fears were probably spilling coffee on your drawing or the cat walking across it. Now, you are going to be relying on your computer for the delivery of projects, and computers *can fail* sometimes. You need to be sure that your project files are backed up. Vectorworks can handle this automatically for you. The settings I recommend are:

1. Set Autosave every 5 minutes (or less).
2. Switch OFF Confirm before save so that you don't have to keep responding to prompts on the screen.
3. Save to a backup folder in the same location as the original file. This means you will be responsible for manually saving the main file, but you will have a backup automatically saved. You will use twice the disk space, but disk space is *cheap* compared to the cost of a lost project.

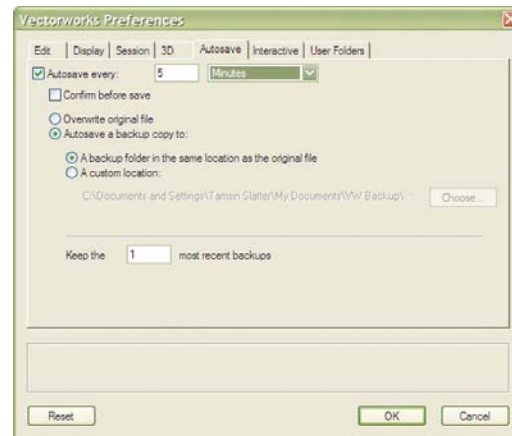

4. Your alternative is to back up to a custom location, such as a separate backup folder where you keep all your backed-up files. It's more effort to find them, but could make it easier to keep an offline backup (onto an external storage device).

Interactive Tab

This tab allows you to control what the cursor on the screen shows you. The 2009 cursor offers many helpful hints on the screen, making it easy to select drawn objects, line objects up with others, and much more. There are further settings that work in conjunction with these.

1. Set your preferences as follows:
2. Click on the Interactive Appearance Settings button to view the colors of the information on the screen. For now, I suggest you leave them as they are until you're familiar with their meaning, but remember that you can change them later if you wish.

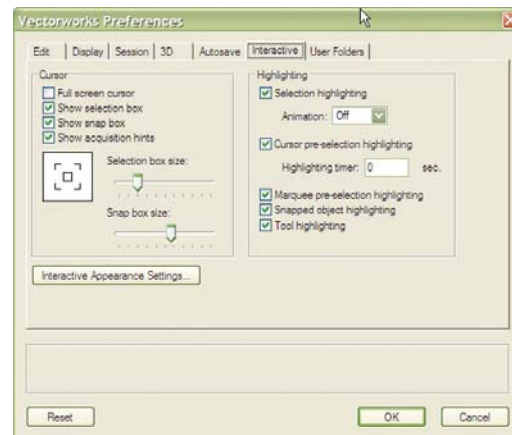

User Folders

This contains the default location on the disk where Vectorworks will store the preferences you are setting, along with any templates you



create. Generally, there is no need to change this at all unless you particularly want them stored elsewhere. This folder location also stores files such as the Vectorworks log which shows which files you opened and when—very useful for billing your clients! You can browse this folder by clicking on the Browse button.

Exercise Three: Managing Other Vectorworks Settings

Constraints Palette

The Constraints palette helps you to draw more accurately and “constraint” drawn objects to certain parameters—such as forcing lines to be horizontal, at 45°, etc. It also ensures that helpful hints are displayed on the screen to ensure you have selected the correct point.

1. Double-click on any one of the buttons on the Constraints palette and then review the menu items. We will be changing various items as we move through the book, so for now, just get familiar with accessing the menu, and then leave the palette looking like this:
2. To switch buttons on, click on them. A border will appear around the button when it is switched on. Click on it again to switch it off. The first five buttons will be beneficial when you are drawing. The last three will only be switched on when you specifically need them.

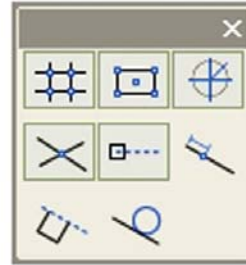

Note: By default, the Constraints palette is floating. If you are working on a PC, you can dock the Constraints palette if you wish by dragging its heading to the top or the left of your main application window.

Color Palette Libraries

I think one of the strongest criticisms of CAD in general is that the colors appear flat and limited and cannot replace the beauty of hand-drawing. If you spend some time getting to know the color palette options and later the gradient, hatch and stipple tools, you will be able to create very artistic effects. For now, we'll look at the color palette and make some of the libraries available. The color palette allows you to select any color you like – but you can also select from specific published color libraries such as PANTONE®.

1. On the Attributes Palette, click on the white bar which displays Solid Fill Color.
2. Click on the Color Palette manager (spanner/wrench and pencil button) on the top right.
3. Select other color libraries you would like to make available in all your drawings by clicking in the Active column so that a check–mark appears. Note that there are Pantone® libraries and other well-known libraries. Click OK.



- Click on the color bar again and note that the new libraries are now available for selection. These will now be available each time you use Vectorworks.

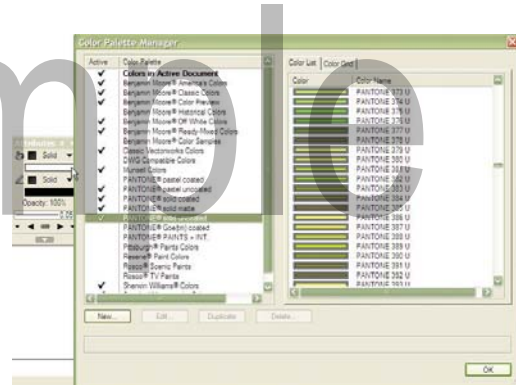

Exercise Four: Set Default Font

There is a range of text tools available within Vectorworks for adding annotations to your drawings. These will be covered in detail in a later chapter. However, for now we're going to choose your favorite font to set it as the default font, so it's used each time you add some text to the drawing. Of course, you can override the font settings for individual pieces of text.

- On the Text menu, choose Format Text.
- Choose your favorite font and the size at which you would like it to print. Vectorworks will remember this from one session to the next, so once set, it should stay set.

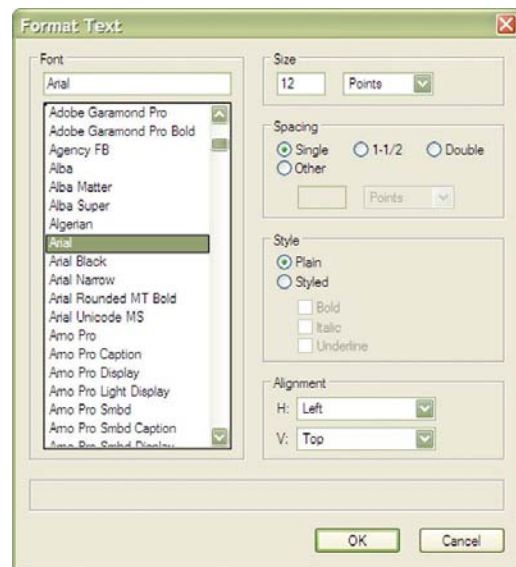

Document Preferences

Document preferences, unlike Vectorworks Preferences, are settings that are relevant to the current file only. These include the layer scale; the units of measure for length, area, volume and angle; and the paper size. In order to make these settings available at the start of each new drawing, you will need to amend them and save the blank file as a template. This is easily done with Save as Template command from the File menu.

Exercise Five: Set Up Your “Drawing Board” and Save Your Template

Open the Document Setup Dialog Box

This dialog box is found in Document Settings under the file menu. It allows you to set up the Units of measurement for the file, the scale of the file, the size of the grid – and whether or not the grid is visible. You can also specify the default Drawing Border style and Title Block here, but you can also make changes to this later.

- From the File menu, choose Documents Settings / Document Setup.

Set Your Unit of Measure

The unit measurement is important because it determines the “real world” size of the objects you draw. It’s also critical when importing drawings from other CAD systems. Choosing the correct unit of measure for the incoming file ensures that objects are sized correctly when they arrive in Vectorworks. When you set your units of measure, you also determine the number of decimal places that will be displayed (if any). For example, I suggest you display angles with a precision of 1 rather than 1.00. Your contractor may not appreciate being asked to set out the garden with angles of 45.32 degrees!

1. Within Document Setup, to the right of the Drawing Units setting, click on Change.
2. Choose the unit of measure you prefer to work in:
 - If working in metric, I prefer mm for lengths, m2 for areas, m3 for volume and degrees for angles. Choose also the number of decimal places (precision) that you would like displayed for each of these values – (e.g., if you only want lengths displayed in whole mm, choose 1 in the Decimal Precision box).
 - If working in imperial, you’ll probably want to choose feet and inches for length, square feet for area and cubic yards for volume. Choose Fractional precision for rounding and choose the size of the fractions for rounding (e.g., 1/8”). As with metric, choose the appropriate number of decimal places.
3. If using Decimal rounding (i.e., working in metric), you have the option to choose Leading and Trailing zeros for values (e.g. if an area measured 2 m2, this could be displayed as either 2 or 2.00 for consistency with other values on the drawing. I recommend you do this to avoid confusion. Similarly, a value of .25 m2 would be displayed as 0.25 m2 to ensure that the decimal point is not missed when reading your plan).
4. Click OK, returning to the Document Setup dialog box.

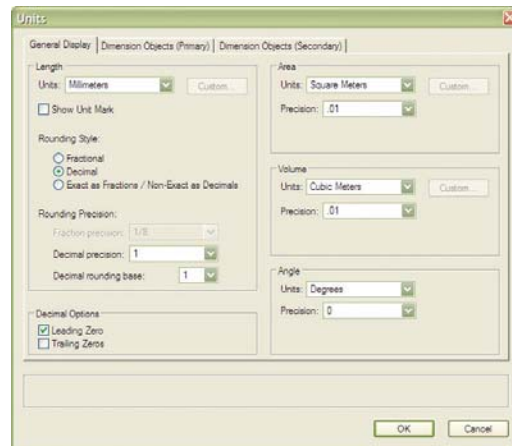

Set Your Default Scale

1. To the right of the Layer Scale, click Change and set your default scale. You aren’t stuck with this scale, but it’s a good idea to choose the scale that you most commonly work in. You can always change it and you can view different elements of the garden at different scales anyway.
2. If you want to use a scale that is not listed in the boxes, you can enter your own custom scale in the Paper Scale box.



- Metric users will probably use a scale of 1:100 or 1:50.
- Imperial users will probably be working at something like one quarter inch to a foot (1/4"=1'-0") (1:48) or one-eighth-inch-to-the-foot (1/8"=1'-0") (1:96).

3. The All Layers box is not ticked by default. Any new layers created in the drawing will use the scale you have set above. However, if you wish to change the scale of a drawing and it has many layers, you will need to tick this box so that your changes will affect *all* layers. Having said that, it's possible to have many layers at different scales in the same drawing.

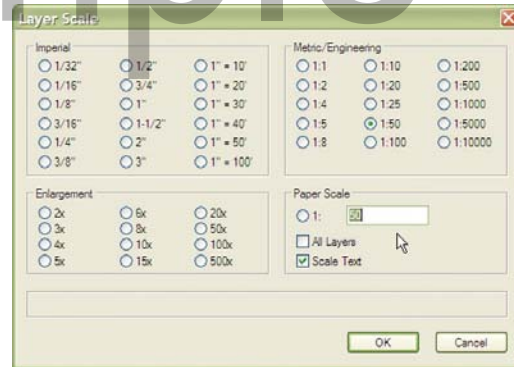

4. There is a scale text box that is ticked by default. This means that if you later change the scale of the drawing because you realize the site won't fit on the page, any text you have added will be scaled with the drawing. I recommend that you uncheck this box. Since you have chosen a default font *and* size for this font, you probably don't want it to be rescaled and you want the text to remain the size you chose in the text setup.

5. Click OK, returning to the Document Setup window.

Set Your Drawing Area / Paper Size

Now we're going to set the paper size for the drawing. You may have a printer in your office that can cope with the size of drawing you want to produce; in which case your computer will have a driver installed telling it all about the capabilities of your printer. However, many of us don't have access to a large format printer and will be emailing our drawings to a print bureau. If this is your case, you need to choose the correct paper size before sending it. Vectorworks has options to cater to both these scenarios.

Also, you'll use different paper size standards depending on where you are in the world so this exercise will cater for both imperial and metric standards.

1. On the Document Setup dialog box, next to Drawing Area, click Change.
2. If you have a large format printer available in your office, and its driver is installed on your computer, click on Printer Setup to get to the printer's own dialog box and choose the appropriate page size from there. Ensure that One Printer Page shows up in the box at the top right of the Drawing Area dialog. The dimensions of the page will reflect the printable area as defined by your printer driver.
3. If you are sending your files to a bureau, you will need to choose a paper size that your computer may not understand. For example, I have a printer that can print A4. Therefore, it can't print and doesn't understand A1. Click on Choose Size Unavailable in Printer Setup, and then select your desired paper size.





4. On the left of the dialog box, tick Show Page Boundary so that you will be able to see the edge of the page on your screen. Your drawing space is huge, but only things drawn within the paper area will print. Therefore it's useful to see where that is!
5. Ensure that Show Page Breaks is unchecked. If you are using your own large format printer, and have set the paper size accordingly, page breaks won't cause you a problem. However, if you have for example, an A4/letter size printer on your system but want to print at ISO A1 (US Arch D) size, Vectorworks will helpfully show you where the page breaks would be for printing on the smaller printer. one of my most frequently asked questions is, "Where did this strange grid come from?"
6. Click OK to return to the Document Setup Window.

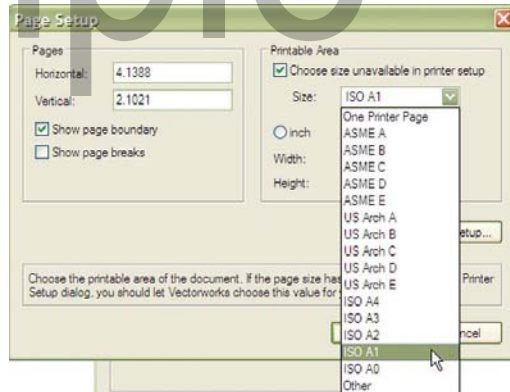

Set Up a Grid

Many designers choose to work with a visual grid to help them break up the space and ensure they are designing things that are a reasonable size. On a traditional drawing board, this might be a hand-drawn grid or sheet of graph paper stuck to the board under a piece of tracing paper. Vectorworks caters for this option, calling it a Reference Grid. Vectorworks also allows you to set a different type of grid, called a Snap Grid, which forces you to draw things to sensible dimensions. For example, I have set mine to 1mm meaning that if I draw something, its dimensions will only be in whole mm. An imperial equivalent might be 1/16".

1. On the Document Setup dialog, click on Change to the right of Drawing Grids. This will open the Smart Cursor settings dialog box.
2. Click on Grid from the list on the left and then make the following changes:
 - Set the snap grid to 1mm or 0.125 for 1/16".
 - Change the reference grid to 2000mm (6').
 - If you regularly use a grid, check Show Grid Lines.
 - If you don't, ensure Show Grid Lines isn't checked. You will have a grid available should you wish to view it later.

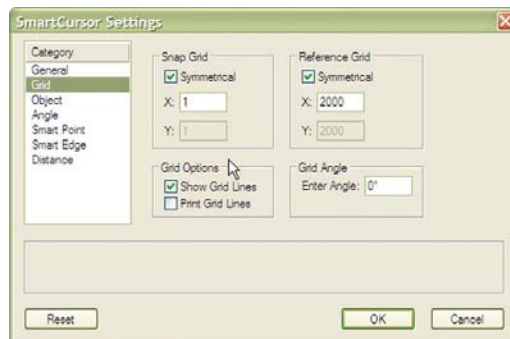

3. Click OK and then Click OK again to return to the drawing.

Set Up Auto-classing

I mentioned earlier in this chapter that you might not yet be feeling confident about classes. However, for now, take my word for it that they are going to make your life easier and Auto-classing is a really useful feature of the document setup. It instructs Vectorworks to automatically create certain classes (from a predefined list) when you create certain objects. This means you can be really organized without having to make the effort!

1. In File/Document Settings/Standard Naming, tick the Auto-classing box. You will see a message asking if you want to Auto-class existing objects in the file. Click OK.

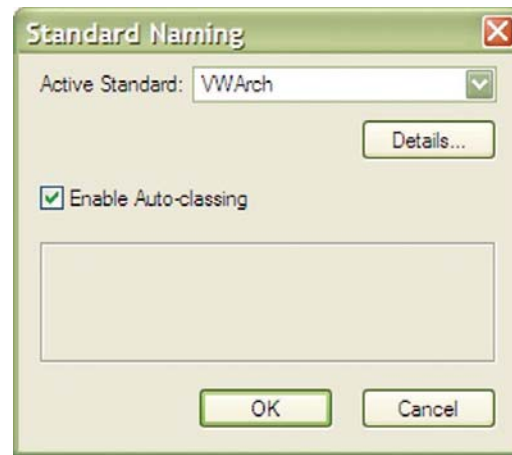

Set Up Dimension Preferences

You can also set a specific standard for the way dimensions appear – or you can create your own new one and edit it to your precise requirements.

1. From the File menu, select Document Settings then Document Preferences. Choose the Dimensions Tab.
2. Check all the boxes to ensure dimensions remain associated with the objects they are measuring. Then, if the objects change size, the dimensions will be updated with them.
3. Click the box to ensure that all dimensions are created in the Dimension class. This means you can control whether or not dimensions are visible later when you learn more about classes.

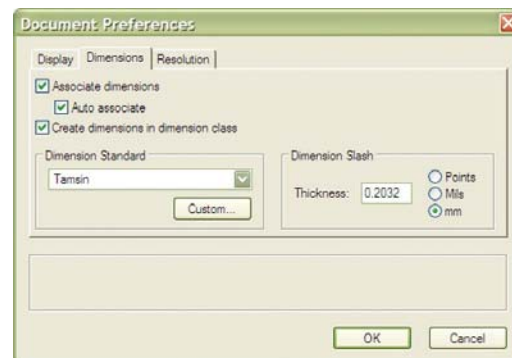

Save Your File as a Template

Now that you've set up the file as you prefer, you can make the file available as a template so that you don't need to go through the setup each time you start a new project.

Clearly there is a lot more to learn about customizing Vectorworks than we've covered yet, but as we go through the course I'll advise you to update your template when we learn something new that would be appropriate to save.



1. From the File menu, choose Save as Template. Vectorworks will automatically place your file in the directory where it keeps all the default templates. Give your template a sensible name such as "A1 1to100" (ARCHD 1 eighth= 1 foot), then click OK. You can't use the :, " or ' characters in your filename.

Use Your Template When Starting a New Project

1. To make use of the template, choose File / New (or CTRL/⌘ + N) and click on the Use Document Template button. Choose your template by name from the drop-down box.





Sample





Adding Color and Pattern to Objects

When I first started using Vectorworks, one of the criticisms I often heard from those who hadn't yet made the leap to a computer aided design system, was that the colors were bland and flat. However, I soon discovered that with a little effort I could create some lovely effects that look hand-drawn. In this chapter, you'll learn all about the graphic effects available for 2D objects. Once you've mastered these basics, you will be able to move on to some of the more specialized tools in Vectorworks Landmark, such as those for Hard Landscaping and Planting, both of which employ these graphic techniques and, in many cases, allow you to combine them to create more interesting effects.

The Attributes Palette

There is a palette floating on your screen called the Attributes palette which looks like this.

It allows you to set the default graphic qualities for 2D objects that you haven't yet drawn. With the Attributes palette set as it is shown here (the default), I've drawn a circle that has adopted the attributes shown in the palette—a fill of solid white color and an edge of solid black, with a pen thickness of 0.05 mm. The opacity of the object is 100%. Opacity, being the opposite of transparency, means this object has no transparency and will completely cover anything it overlaps on your drawing—in this case, the drawing grid.

I've then selected the same circle and used the Attributes palette to change the fill, pen and opacity of the circle. Instead of using a solid color, the circle is now filled by a gradient (a blend of two or more colors) and has a solid gray pen with a thickness of 0.25 mm. Opacity has been reduced to 80% so the grid is partly visible behind the object. This will be very handy later when you add some trees to a design and want to be able to see through the canopy.

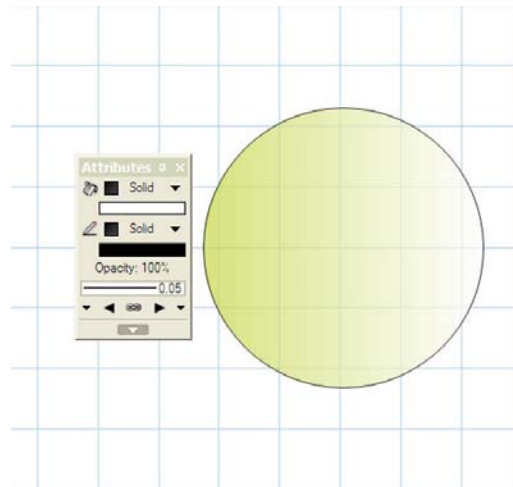
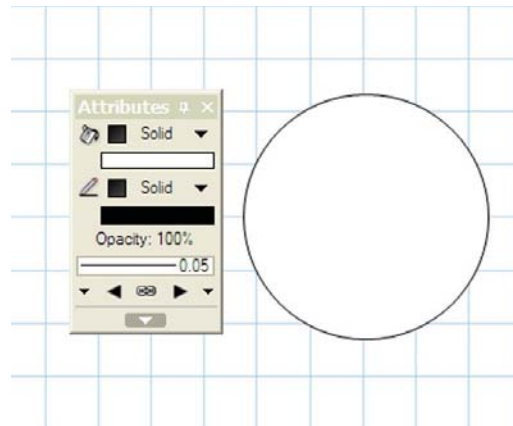

Exercise Six: Applying Graphic Attributes to 2D Objects

Setting basic attributes for an object is easy. The choices available on the Attribute palette initially are limited to what Vectorworks calls “Default Content,” a limited list, designed to get you started. Later, you’ll see how to extend this list using the extensive libraries that Vectorworks has installed for you. You’ll just need to know where to find them and I’ll show you that later.

1. Open the exercise file “Graphic Attributes.vwx”. In this file, you will find several simple shapes.

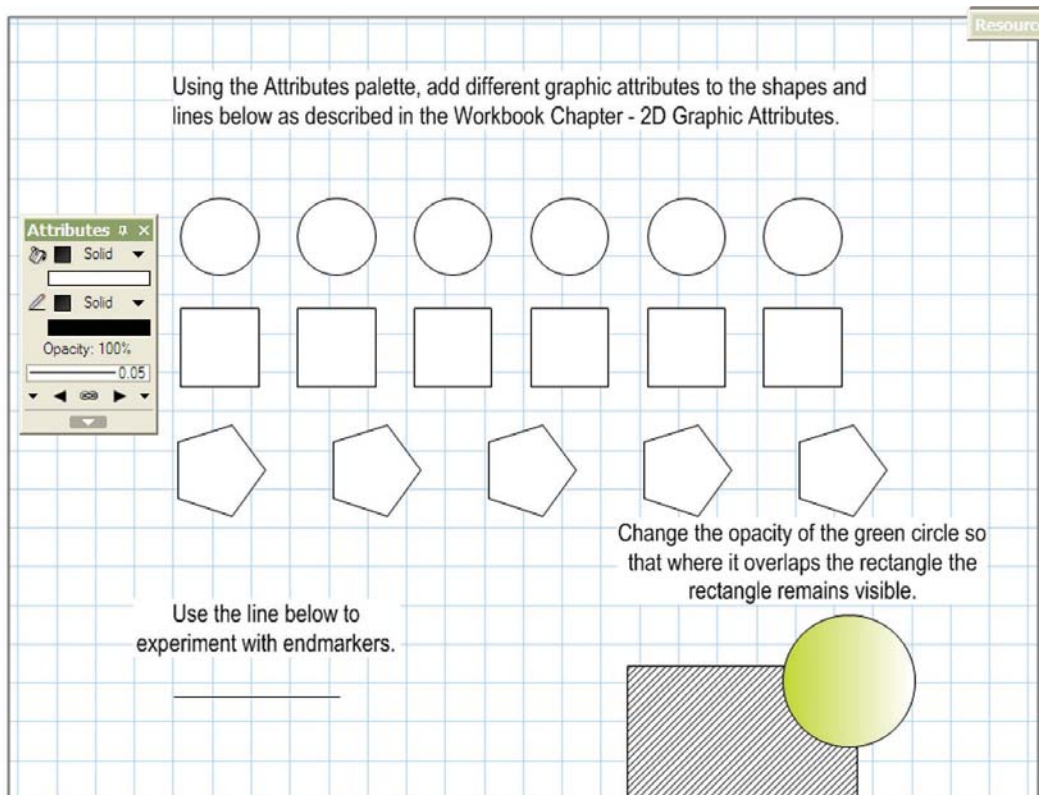

Applying a Fill of None

1. Move the cursor over one of the objects and click to select it. Change the fill to None by dropping down the menu to the right of the paint bucket icon on the Attributes palette. The object will just show an edge. Objects underneath this object would still be visible.

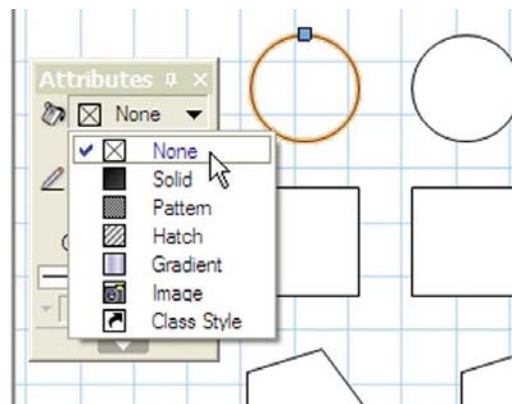



Applying a Solid Color Fill

1. Select another object. Use the attributes palette to change the fill color from white to another color of your choice. In this case I've chosen a muted brown from the Benjamin Moore Ready Mixed color palette which I added in the "Setting up Your Drawing Board" chapter.

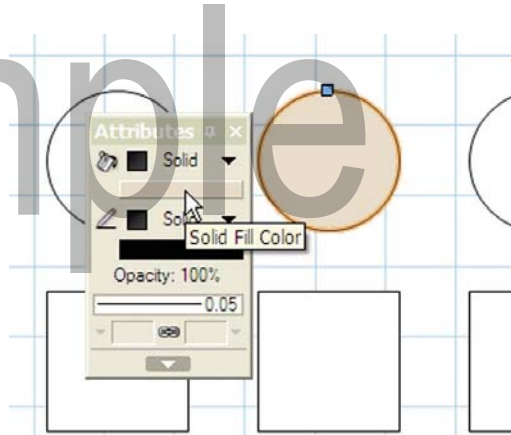

Applying a Pattern

1. Choose another object and fill it with a pattern. Patterns are repeated across the object and there is a range of patterns from which to choose. You can also change the foreground and background color of the pattern. Bitmaps will not change scale if you decide at a later stage to change the scale of your drawing. A hatch is a better option if you want patterns to be scalable.

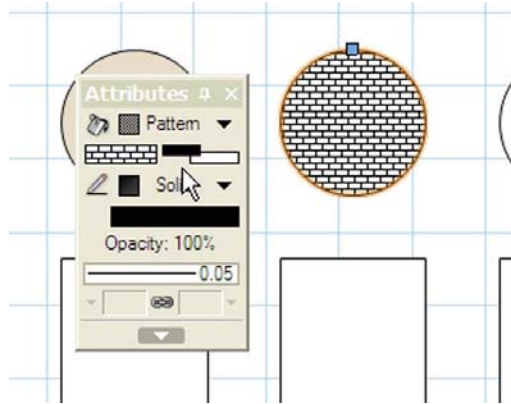

Applying Hatches

1. Select another object and fill it with a hatch. Vectorworks will automatically select the first hatch from the default hatch list (Aluminum). However, if you click on the palette where Aluminum is showing, you can choose a different hatch—try one of the brick hatches. Depending on how the good people at Nemetschek have created these hatches, some of them are "real world" sizes and will show their actual size at the scale of the drawing. If you change the scale, your hatch will scale with it. Hatching via the Attributes palette is called applying an "Associative Hatch". Move one of the objects that you've hatched, and you'll see that the hatch moves with it.
2. However, if you take a look at the way the hatch has been applied, you will see that it has hatched from the center of the object outward. In my case, this means the bottom course of brickwork needs some very careful cutting and probably won't be very stable! So, for a brick hatch, you may want to have more precise control over how the hatch is placed. Select another object (one that doesn't yet have a fill). From the Modify menu, select the Hatch command. Choose the same Brick hatch that you used before. Notice that the cursor has changed to a paint bucket—it's loaded with your choice of hatch and ready to apply it to the object. Position the cursor at the bottom left corner of the square and click. Move the cursor to the bottom right of the square and click again. Notice that the hatch now starts at the bottom of the shape with a complete course of brickwork.





Note: This creates what's known as a "non-associative" hatch. In plain English, the hatch created will be independent of the object you've hatched and is essentially a group of lines that fit your shape. But moving your shape will not move the hatch unless you first select the object AND the hatch, then group them via the Modify menu Group command.

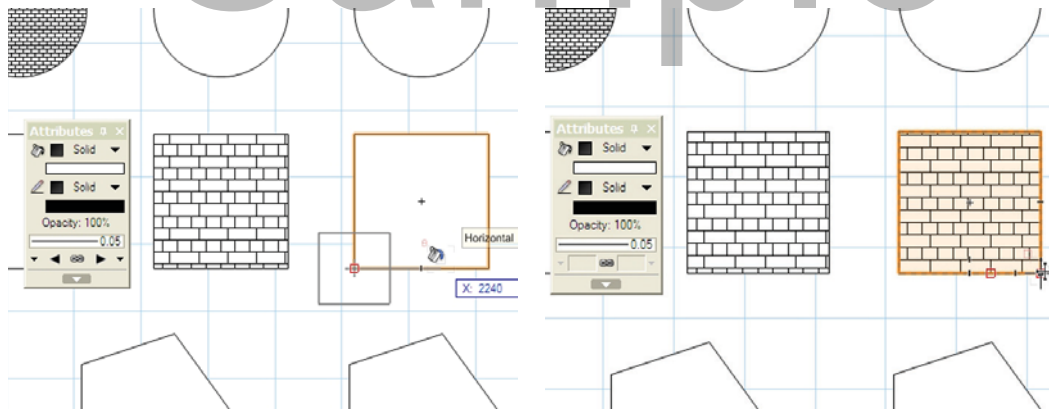

Left image shows hatch applied with the Attributes palette. The right image shows the hatch applied using the Hatch command.



Applying Gradients – Color Blends



Gradients fill the object with a graduated blend of one color into another. Many are provided for you but you can create your own—we'll look at this later. Now you are starting to see that you can render your drawings in a similar way to hand-drawing.

1. Select another object from the Graphic Attributes.vwx file. From the Attributes palette, choose Gradient. Beneath the word gradient, you will now see the top of the default list of gradients has been chosen for you. Click on this to change to a different gradient.
2. Notice that the gradient has applied the color in vertical bands from the left of the shape to the right. This is called a linear placement as the color is in vertical lines. Click on the Fill Gradient settings button on the Attributes palette.
3. Notice that you can change the gradient here if you wish, and change the style of gradient. Choose Foliage Light Green. Change the gradient type to Radial and press the Preview button. Notice that the gradient colors now bend around a central point and that this central point is on the left of the object. Change the X offset value to -50mm (-2")

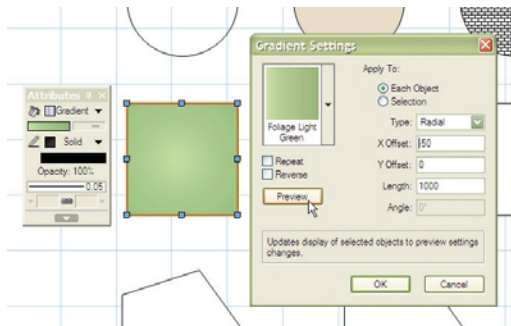



Applying a “Photorealistic” Image Fill

An Image Fill fills an object with a bitmapped image. The Image Settings dialog box provides options for applying them.

1. Select another object from the Graphic Attributes.vwx file. From the Attributes palette select a fill type of Image. Then from the Image selection below, choose Brick Paver Red IF. This will be available in the Default Image list.
2. Now, as you did with the gradient, change the settings of the image using the Fill Settings button on the Attributes palette (ensuring first that the object you’ve just filled is still selected). Change the rotation of the image to 45° and then click OK.

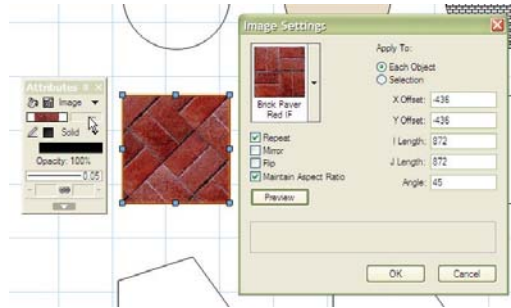

Changing Pen Settings

The pen Attributes choices are similar to those available for fills in that you can choose from solid, pattern, or dashed settings. The color options are also the same. In this exercise, you’ll learn how to change the line style, the line thickness, color and end markers.

1. Select another object from the Graphic Attributes.vwx file. Click on the Line Style box on the Attributes palette and choose a thicker pen, then choose a dashed line style.
2. Select the horizontal line at the bottom of the Graphic Attributes.vwx file. On the Attributes palette, click on both the Line Start Marker Toggle and the Line End Marker Toggle buttons. This switches on end markers for both ends of the line. You can now select the end markers you want by choosing from the Line Startpoint Style and Line Endpoint Style drop-down lists. You can choose different end markers for each end of the line.

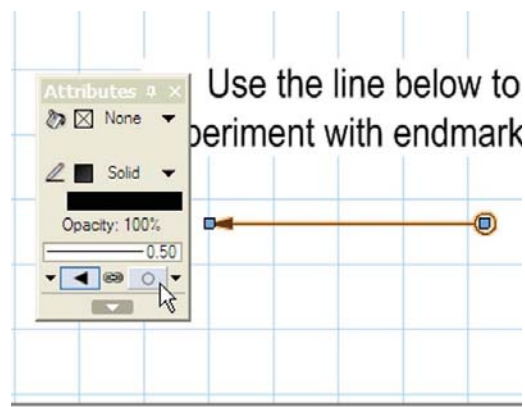
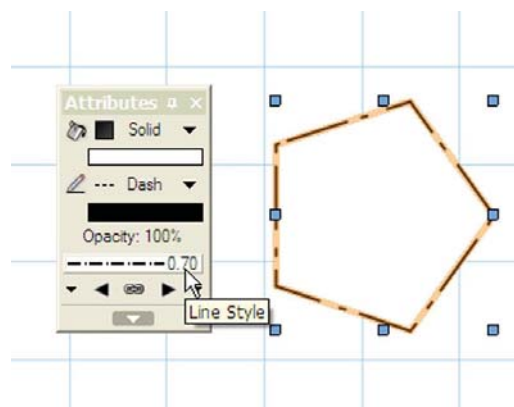

Note: If you want to refer to line thickness in a measurement other than millimeters. Line styles can be referred to by their size in points, or mils, or millimeters. To change the way Vectorworks describes your line style, go to the Tools menu, select Options and then Line





Thickness. On this palette, you can also choose which line styles are shown in which order on your Attributes palette.

Changing an Object's Opacity

With the opacity setting, you can adjust the transparency of individual 2D objects with the Attributes palette, or by using class attributes.

1. At the bottom right of the Graphic Attributes.vwx file, there is a green circle overlapping a rectangle that has a hatched fill. Select the green circle.
2. On the Attributes palette, click on the button that says Opacity 100%. Change the value to 80% either by typing the new value or by moving the slider button. Click Set Opacity.

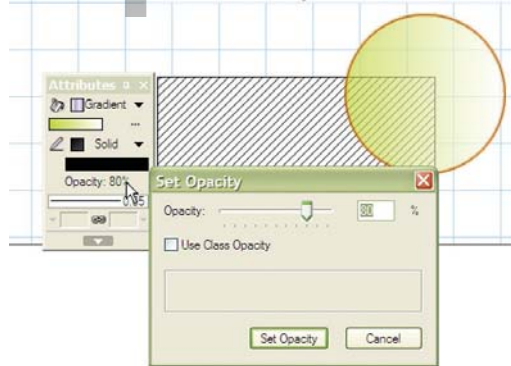

Note: All of the above methods apply to 2D objects only. Unless you have Renderworks, you will only be able to apply solid fill colors to 3D objects. However, Vectorworks has some great tools for creating objects that behave both as 2D and 3D objects—called Hybrids. You'll learn more about these as you move through the book. They make adding hard landscaping—as well as planting, and other garden structures—to your design easy.

Changing the Default Values on the Attributes Palette

Now that you know how to change the values on the Attributes palette and apply the different options to individual objects, we're going to look at the palette itself and see how you can permanently change the default values (white solid fill, black solid pen with .05mm thickness). As I mentioned above, I have seen occasions where a .05 line will not print on some printers. Therefore, it's my recommendation that you change this to something higher. When drawing by hand, you probably used a .18 mm pen or maybe a .13mm if you were less clumsy than I am.

1. Make sure you have nothing selected (click on a blank space on the drawing area.) Verify nothing is selected by looking at the Object Info palette which should say, "No Selection". It's important that nothing is selected; otherwise your changes will apply to the selected object.
2. Change the Attributes palette Pen Line Style to a solid black line with .18mm thickness (or .13mm if you prefer).
3. On the bottom of the palette, you will see a small arrow. Click on the arrow to reveal the menu.
4. Choose Set Default Attributes. You will now only get a .05 mm line if you specifically want it.





- From the File menu, choose Save As and give the file a name “My Graphic Attributes” if you wish. This will leave the original exercise clean should you decide to run through it again. Close the file using Close from the File menu.

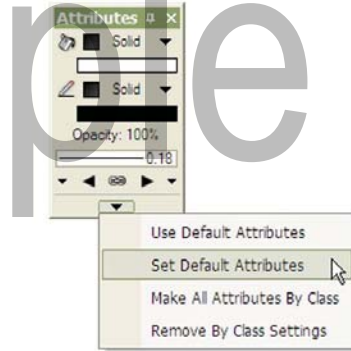

Adding a “Stipple” Effect to an Object

The graphics we’ve looked at so far apply quite uniform effects to objects. Hatches are a predetermined series of regular lines, for example. But as a garden and landscape designer, you will often want to replicate the effect of dotting your pencil or pen over an area to denote long grass.

This exercise will show you how to use the stipple tool to create such areas. You create a stipple by using a specific tool—the Stipple tool—which you’ll find in the Dims and Notes palette.

- Open the file Graphic Attributes—Stippling.vwx.
- Click on the Stipple tool in the Dims/Notes palette and then note the options available on the Tool Bar: They are the same as those for the Polyline tool. Choose the corner vertices. Then click on the Preferences button (the one with the wrench and pencil) to define your stipple choices.
- Your stipple can contain a mixture of up to two shapes, which will be generated at random within parameters that you specify. For this stipple, we are going to use just one shape. Leave the default settings in place with the following exceptions:
 - World Dimensions:** This means that any measurements used to define the stipple relate to real-world sizes (and the stipple will rescale if you change the scale of the drawing).
 - Fade Stipple from Edge:** Set a stipple width of 1000mm (3'). This will reduce the density of your stipple towards the middle of the area.
- Trace over the edge of the Rectangle to apply your stipple, using the Point cue on the screen to help you draw with accuracy.
- Save the file using the Save As option from the File menu. Call it My Graphics – Stipple.vwx and then close it using the Close option on the File menu.

Note: You can further soften the effect of the stipples by using paler gray colors instead of the solid black shown here.



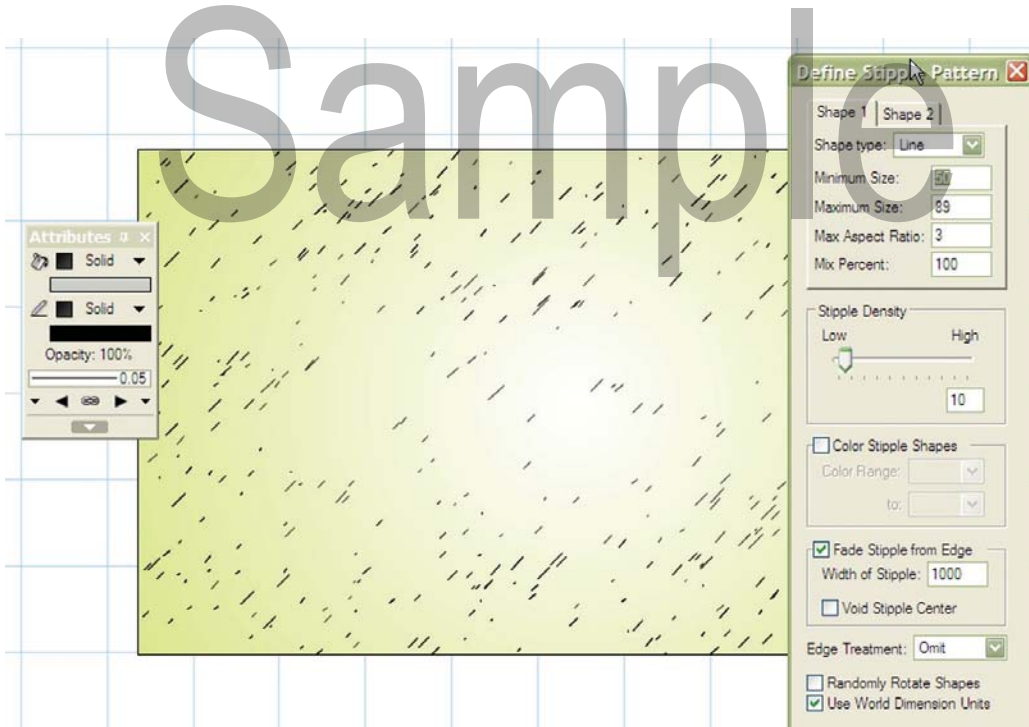

Rectangle with stipple applied over the top, together with dialog box to create the same stipple.

Adding Irregular Patterns to Objects Using the Tile Command

You've seen that you can hatch objects. Hatch patterns are regular patterns, made up of straight lines. These are great for paving where the pattern is regular. However, if you want to create a pattern that is less regular, you can use the Tile command. Vectorworks provides a series of "tiles" for you to use. You can create your own by creating new symbols. You will learn how to do this later when learning about the Resource Browser.

1. Open the file Graphic Attributes – Tiling.vwx. You will see a rectangle with a gray gradient fill. You are now going to add an irregular paving pattern over the top
2. Select the rectangle. From the Modify menu, select the Tile command.
3. From the drop down menu on the dialog box, select Granite – Large. Ensure that Clear Undo History is ticked. This will speed the process. (Tiling a large area can take your computer a long time as it requires a lot of thinking time!)
4. Click OK. The object will tile. Again, bear in mind this can take a while and could even be time to make a cup of tea if the area is large. This exercise step won't allow you enough time for tea though!

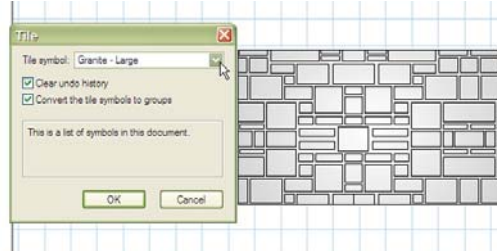



Sample

5. Save the file with a new name such as “My Graphics – Tiles.vwx” and close it using Close from the File menu.

How to get Vectorworks to Remember your Favorite Graphics

Earlier I told you that there were some things you probably weren't feeling 100% convinced about yet? Classes are probably one of those things. I have to confess that when I first read the word “classes” when I evaluated Vectorworks, horrible memories of programming courses during my previous career sprang to mind. But classes are really not scary things at all. In fact, they are incredibly useful! If you've used desktop publishing systems before, or even used styles in Word, you'll find the concept is similar. If you haven't, still don't panic. Classes are just named containers that hold graphic attributes. For example, you could create a class called decking, and within that class, define the graphic attributes you want to apply to decking each time you draw it. You will learn much more about this in the chapter on Adding Hard Landscaping.

1. Open the file Graphic Attributes Using Classes.vwx.
2. On the Navigation palette, click on the left-most tab – Classes. Note that I have created a class here called Paving. Click on its name to highlight it and then click your right mouse button, choosing edit from the context menu.
3. Notice that the class has a solid gray fill set. Click OK to close the class.
4. Select the rectangle. Via the Object Info palette notice that the current class is “None”. Drop down the list to the right of the class name, to access other classes available in this file. Choose Paving.
5. Note that the rectangle has now inherited the graphic properties of the paving class.
6. Using the same technique, select the circle and change its class to Tree Canopy.
7. Save a copy of the file if you wish, calling it My Graphics Classes.vwx and close it.

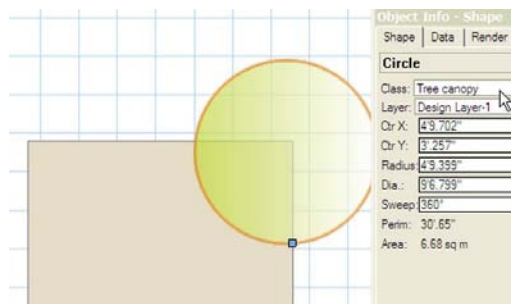
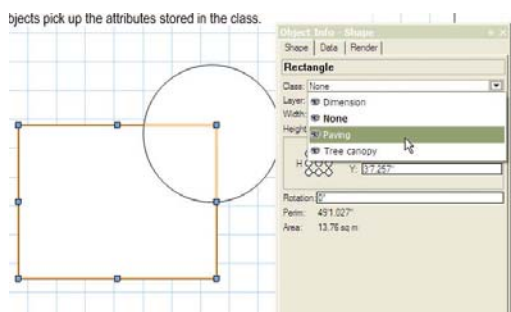
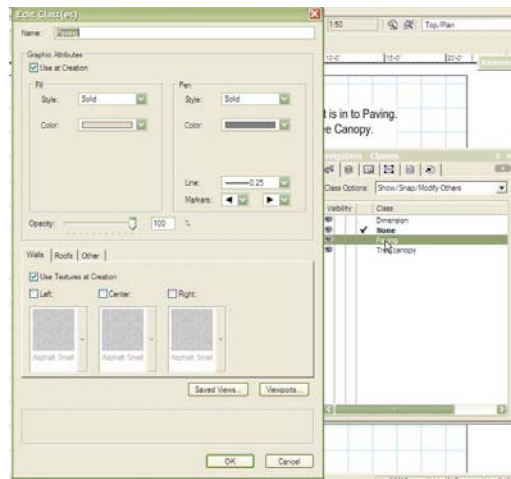



Note: Graphics such as Stipples are handled slightly differently. They can't live in classes – but they can be stored as “Resources”. See the chapter on Setting up Your Resource Browser for more information.

Sample

